



Multi-Deur BV

Manual

Springs in front



The Solid-S500 Garagedoor

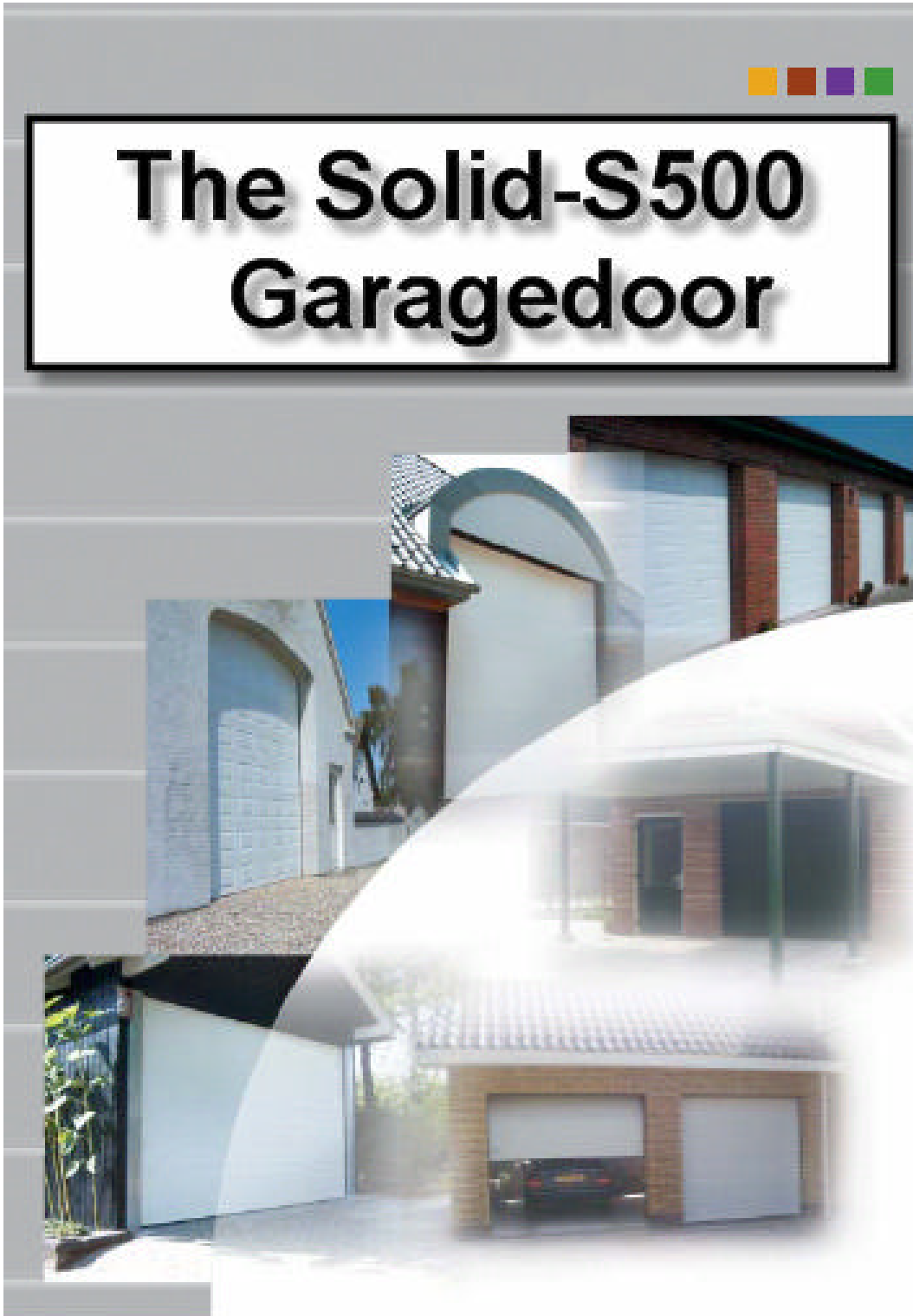

Contents:

1	General	3
1.1	End user obligations	3
1.2	Safety instructions for installation, initial operation and maintenance	3
1.3	Guarantee and liability	4
2	Use	4
3	Directives and standards (only applies to doors with an electric drive unit).....	4
3.1	Certification	4
4	Installation.....	5
4.1	Installation preparation	5
4.2	Installation tools and accessories	6
4.3	Fitting the back hangs and corner brackets.....	6
4.4	Fitting the horizontal rails	7
4.5	Hanging the door	8
4.6	Fitting the C-rail	9
4.7	Fitting the top header seal	9
4.8	Fitting the springs and shaft	9
4.9	Fitting the panels	10
4.10	Fitting the cable and positioning the cable drum	11
4.11	Tensioning the spring assembly	11
4.12	Correcting the spring tension.....	12
4.13	Fitting the drive unit.....	13
4.14	Adjusting the drive unit	13
4.15	Placing the CE mark	13
5	Technical specifications.....	13
6	Installation and initial operation	13
7	Drive unit.....	14
7.1	Electrical drive unit.....	14
7.2	Manual operation	14
8	Maintenance.....	14
8.1	General	14
8.2	Care.....	14
	Inspection/service	15
8.3	Troubleshooting.....	15
9	Putting the door out of operation/dismantlement/disposal	15
9.1	Putting the door out of operation (only applies to electrically powered models).....	15
9.2	Dismantlement	16
9.3	Disposal	16
10	The manufacturer.....	17

User manual

To avoid serious personal injury, you must carefully read and observe all directions and instructions in this manual.

1 General

- This rail set was designed in accordance with the applicable CE standards. You should, however, check whether these standards are in line with your local national standards.
- The materials required for fitting the rail set against a wall and/or ceiling is not part of the rail set!
- All instructions concerning right or left installation should be seen from in the garage looking outside!
- Unless stated otherwise, all sizes are in millimetres.
- Subject to technical modifications.



1.1 End user obligations

- The end user is obliged to ensure that the instructions in this manual are followed.
- This garage door should only be operated by people who are considered competent to do so.

These are people who:

- Have built up a specific level of knowledge by being provided with information (for example, by reading this manual) about how the door works.
- Possess the skills required for operating the door.
- People aged 12 and older.
- In principle, no people, animals or other objects may be in the door opening when the door is electrically or manually operated.
- If any problems related to the door occur, you should always call in a qualified service engineer!
- This garage door may not be modified in any way!
- If the door's electric drive unit no longer works (properly), the door must only be operated manually.
- Make absolutely sure that your garage door is in complete working order and have the safety devices regularly checked (immediately after installation and at least once per year) by a qualified company and maintain written records of when the door is serviced.
- Inspect your garage door visually at least once per month for damage that could affect the way it works.
- Never reach into moving parts or the door mechanism when it is working!



1.2 Safety instructions for installation, initial operation and maintenance

- The garage door may only be installed, connected and operated for the first time by professional fitters.
- When working on the electrical system, always make sure that the current is switched off!
- Never bridge safety devices!
- Never operate the garage door if it or its supporting systems are damaged.
- Always wear gloves and safety shoes during installation/maintenance, and safety glasses when carrying out drilling work!
- Always make sure that any platforms, etc. that are needed during installation/maintenance are stable before you use them.

- Mark off the installation/maintenance zone with safety ribbon so that onlookers are kept at a distance.
- Maintenance may only be carried out by a specialist company and/or qualified personnel.
- Make sure there is sufficient light.
- Only use suitable tools. This applies particularly when tensioning the torsion springs.

1.3 Guarantee and liability

If the garage door is not installed by a specialist company, if it is customised by the end user in any way, or if modifications are made to the drive unit that are not in accordance with this manual, the liability or guarantee (as the case may be) of Multi-Deur BV will become null and void. This also applies to damage caused by incorrect operation of the door, not following the instructions in this manual and/or poor maintenance and care.

2 Use

The purpose of a garage door is to close off an opening in a building. This garage door is designed to be installed in garages and on commercial premises to provide safe access for vehicles driven by people.

3 Directives and standards (only applies to doors with an electric drive unit)

The following directives and standards were observed in the design, production and assembly of this garage door:

98/37/EEC	Machinery Directive
89/336/EEC	EMC Directive (modified by 91/263/EEC, 92/31/EEG, 93/68/EEG)
73/23/EEG	Low-voltage Directive (modified by 93/68/EEG)
EN 12604:2000	Mechanical aspects; requirements and classification
EN 12605:2000	Mechanical aspects; test procedure
EN 12445:2000	Safety in use of power operated doors; test methods
EN 12453:2000	Safety in use of power-operated doors; requirements
EN 954-1:1996	Machine safety; control system components that have a safety function
EN 60204-1:1997	Machine safety; electrical equipment
EN 60335-1:1994	Equipment safety ..., general requirements

3.1 Certification

This garage door complies with the set standards and directives. Its conformity has been proven. The respective certificates are available for inspection at the offices of Multi-Deur BV.

4 Installation

4.1 Installation preparation

- Check whether the points where the rail set is to be fitted are on exactly opposite sides of the same plane and that they are structurally strong enough to support the rail set.
- Check whether the floor is level and that it has no irregularities that will prevent the door from opening and closing smoothly.
- Before you start the installation, check whether the door will fit in the garage.
See figure 1.

W = Clearance width
 H = Clearance height
 OH = Overhead room
 Z = Side room

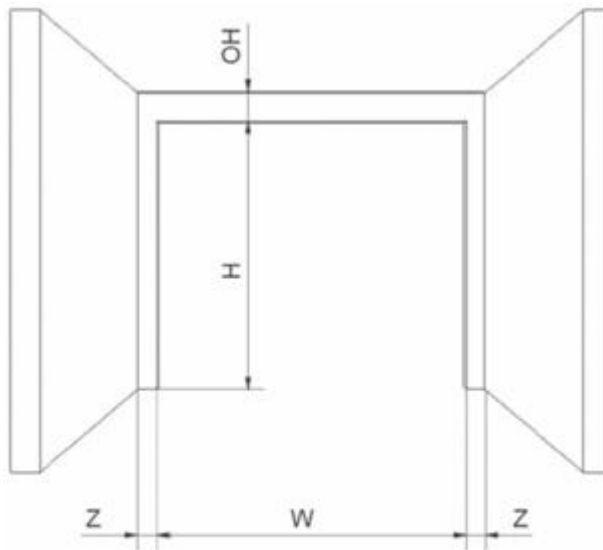
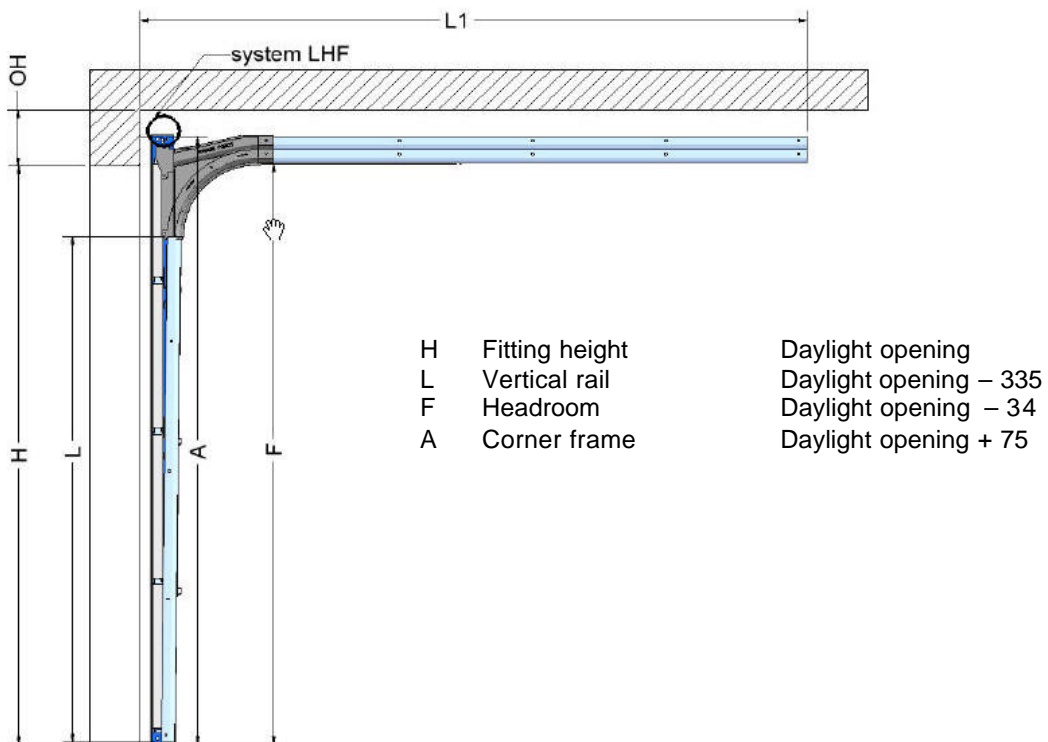

Fig. 1



4.2 Installation tools and accessories

The tools needed for installing the garage door are listed below:

- Spirit (or water) level
- Drill
- Cordless drill/screwdriver
 - Steel drill bit: 4.5 mm/9.0 mm
 - Masonry drill bit: 8 mm or 10 mm
- Ratchet handle plus sockets 10 mm/13 mm
- Ring/open end spanner: 10 – 11 mm/12 – 13mm
- Mole grips x 3 (at least 2)
- approx. 5 m rope

Accessories Rawplugs e.g. FISCHER SX10 SK (set)
 (Not supplied with the door)

- 16 Rawplugs 8 or 10 mm
- 16 hexagonal screws Ø7, SW13, L=60

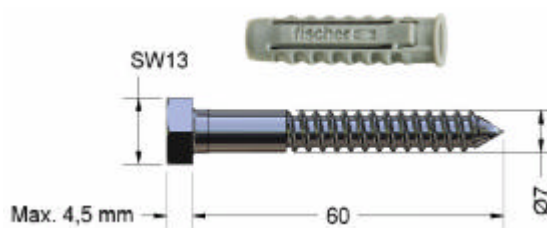

When drilling, always wear safety glasses!
Use a stable and safe ladder!

4.3 Fitting the back hangs and corner brackets

Mark off a line (1) on one wall.
 Place a line on the opposite wall at the same height. (2)
 For the ground alignment, place marks (3) and (4).

Back hang height = H (clearance height) + 75 mm.

Apply a sealant to the sides of the back hangs that will be fitted against the wall.

Fit both back hangs against the wall with their undersides at points (3) and (4) and make sure that they run parallel to each other and that they are level and straight in both directions.
 Fasten the back hangs against the wall in at least 4 places.
 Use 8 or 10 mm Rawplugs with hexagonal screws (Ø 7 mm) to do this.

See figures 2 and 3.

Make sure that both back hangs are parallel and at a right angle to the line between points 3 and 4.

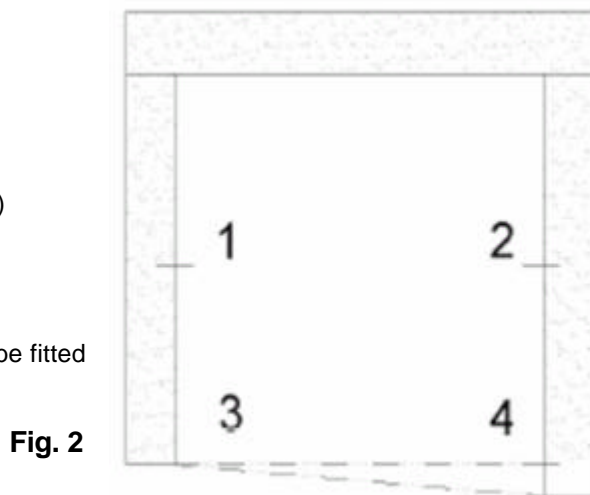

Fig. 2

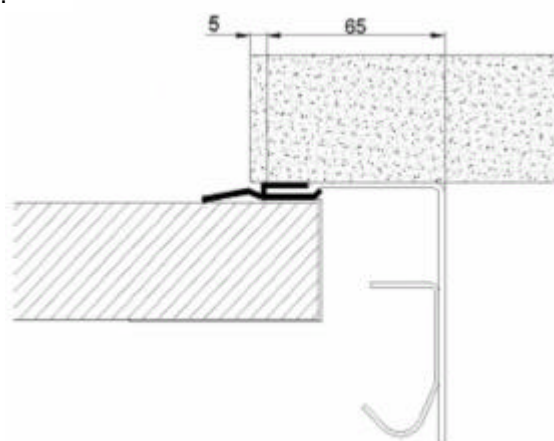

Fig. 3

After this, fit the corner brackets on the back hangs with 4 fillister head bolts and 4 flanged nuts. Use the stops on the corner brackets to ascertain the correct position; the stops are made for door sections that are 38-40 mm wide.

See figure 4.

Take a rail section and slide it into the corner bracket as far as the stop.

Length vertical rail = H (clearance) – 335 mm

Slide the vertical rail into the corner bracket; the correct ground offset is 40 mm. Mark off the required ground offset (section width) on the back hang. Then secure the vertical rail in position with at least 3 fillister head bolts and flanged nuts. Work through this procedure on both the left and right wall.

See figure 5.

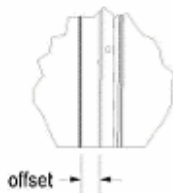

Fig. 5

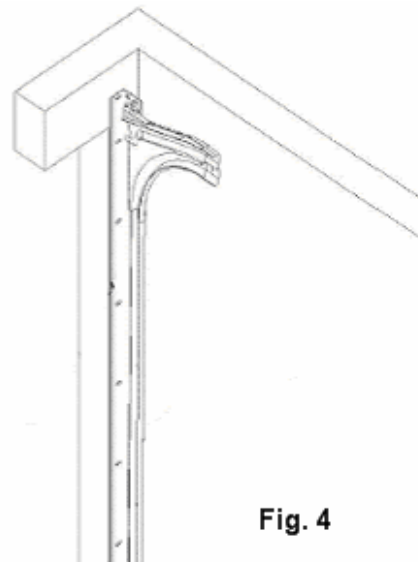

Fig. 4

4.4 Fitting the horizontal rails

Connect both rails side by side to the rail plate with fillister head bolts and flanged nuts. Pay attention to the distance between the fitting positions!

See figure 6.

Fasten a rope to the ceiling or roof construction to support the rear section of the rails.

The rope makes it easier to fit the horizontal rails.

Slide the connected rails into the plastic corner bracket and fasten them with fillister head bolts and flanged nuts.

See figure 7.

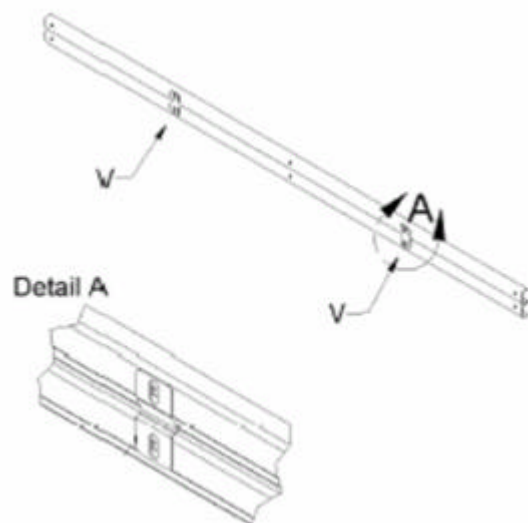

Fig. 6

4.5 Hanging the door

Take two track hangers and click them around the assembled horizontal rails - one on the plastic corner bracket and one at the end of the horizontal rail set. The position in which the door hangs is vitally important for the correct functioning of the rail set! When the door is hung properly, all the forces exerted as the door moves through its cycle will be absorbed by the rail tracks and back hangs.

Now slide the track hangers over a beam in the roof construction and fix it with the extension profile and/or bracket to the horizontal rail set. Following on from this, fasten the door-hanging brackets with 2 hexagonal screws (\varnothing 7 mm) per fixing point to the garage ceiling or roof construction.

If the garage ceiling is made of concrete: use 8 or 10 Rawlplugs (depending on the thickness of the concrete!)

After doing this, untie the rope.

See figure 8.

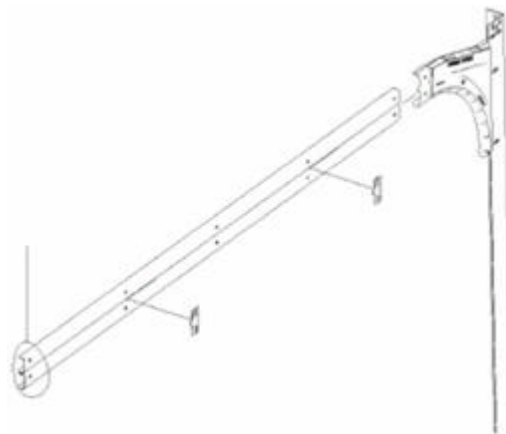

Fig. 7

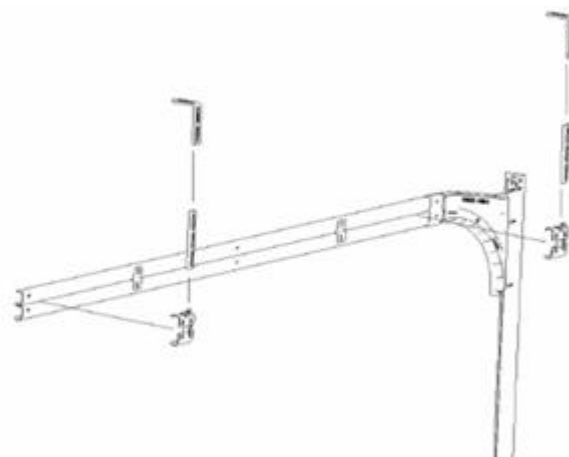

Fig. 8

Then carefully check the following:

The horizontal rail set must be suspended at a right angle to the plane of the door or walls (i.e. angle X must be equal to 90 degrees). Measure lengths C and D and check whether they are equal. If this is not the case, correct the door-hang. Then measure lengths A and B and check whether they are equal. If this is not the case, correct the door-hang. Your rail set should now be properly aligned.

See figure 8.1

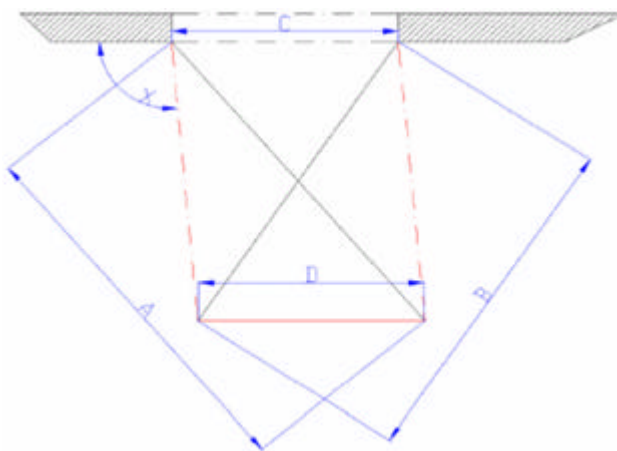

Fig. 8.1

4.6 Fitting the C-rail

If your door is wider than 3000 mm, we advise a horizontal C-rail suspension with holes between the two horizontal rail sets to improve stability. Fit the C-rail to the corner plate with a fillister head bolt and nut. See *figure 8.2*.

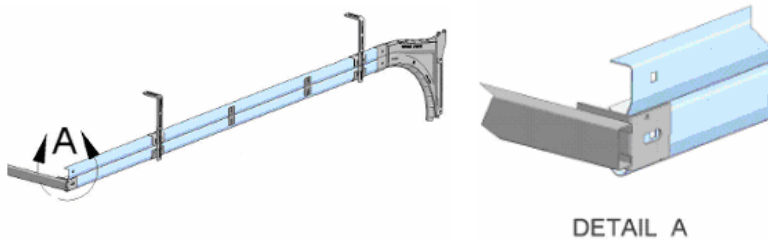

Fig. 8.2

4.7 Fitting the top header seal

On this model, the sealing profile or sealing clip replaces the rubber top header seal. This prevents the rubber top header seal from scraping along the garage ceiling.



Fig. 9

4.8 Fitting the springs and shaft

Before you can start working on the power unit, the LHR consoles must first be fitted to the corner framework. You can do this by positioning the console on the corner frame using the stop. After this, fit the console to the corner frame with 2 fillister head bolts and flanged nuts. It is advisable to secure the console against the wall/top header at additional points (Make sure there is enough room for the cable drum!) See *figure 10*.



Fig. 10

The power unit.

Slide the bearing holder, cable drum, spring-failure safety device assembled springs over the hollow shaft with key in accordance with the diagram below, *figure 11*.



Fig. 11

After this fit the complete power unit in the consoles, making sure that the bearing holders are located outside the consoles. Then fasten the bearing holders to the consoles with 2 fillister head bolts and flanged nuts. Then fit the spring-failure safety device against the top header ensuring that the shaft is level.

Now slide the cable drums into place, but do not fasten them yet. See Figure 12.

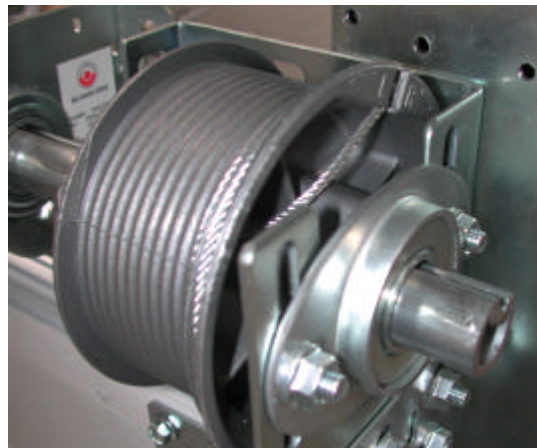

Fig. 12

4.9 Fitting the panels

Fit the ground console on one side and fasten it in position with sheet-metal screws (6.3 x 25 mm). Take the bearing roller with spacer sleeve and cable set and slide it into the ground console. See figure 13.

After doing this, fasten the centre and side hinges. Then insert the ground section into the rail set (making sure it is level - if necessary, fill with a wedge) and assemble the other ground console using the same procedure given above. Now place the middle section on top of the ground section and fasten the centre and side hinges. Repeat this procedure 2x. The type of centre and side hinges that have to be used depends on the panel model. Adjust the nylon runners in such a way that the nylon running surface lies in the curve of the rail and so that there is minimum play between the panel and the side sealing strip. It has to be possible to rotate the nylon runners by hand.

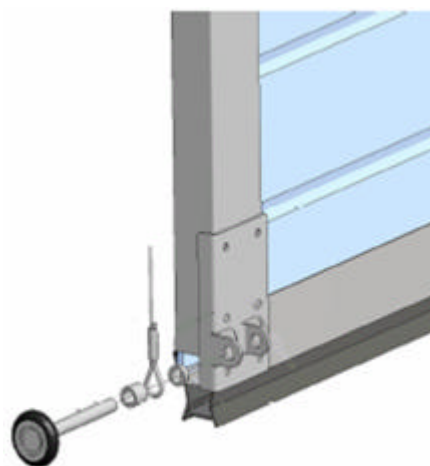

Fig. 13

The top is the last section that has to be installed.

Pay attention to the following:

If you use a top-roller holder, the maximum play that can be allowed between the end cap and the adjustment plate of the top roller holder is 4 mm. See figure 14

Fig. 14



Place the top section on the middle sections and fit the top roller holder as preferred in accordance with *figure 15*.

Fig. 15

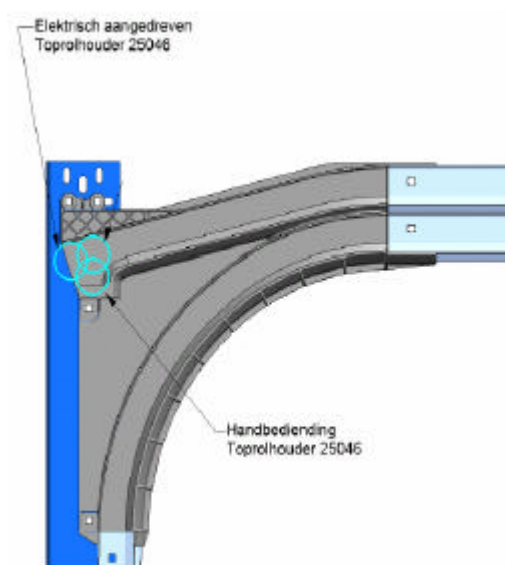

4.10 Fitting the cable and positioning the cable drum

The cable set should already be fitted on the ground consoles (see 4.9, figure 13.2). Feed the cable from the ground consoles behind the bearing roller shafts to the cable drum. Slide the cable end through the cable retention hole on the cable drum and then rotate the drum so that the cable tightens and so that there are at least 2 turns of cable on the drum. After this, fit the key between the shaft and cable drum. See *figure 18*.

Adjust and align the cable drum so that the cable can coil and uncoil freely. Fix the cable drum to the shaft with the fastening bolts (with a torque of 27 to a maximum of 34 Nm). The torque on the cable fastening bolt should be approximately 13 Nm. After this, block the shaft with mole grips and fasten the other cable using the same procedure. It is important that the cables are equally tight and that the door sections are level.



Fig. 18

4.11 Tensioning the spring assembly

Secure the door in position so that it cannot move upwards. You can do this by placing mole grips on the vertical runners. Use the procedure below to tension the springs. The number of “revolutions” that the spring needs to turn is listed on the spring assembly (you can also look at Tabel 1 on page. 12 in this manual). After tensioning, fasten the spring grip to the shaft with a torque of 27 to a maximum of 34 Nm.

IMPORTANT: When tensioning the springs you need to start with the number of turns that are listed on the spring, when necessary you need to adjusted to number of turns until the doorleaf is balanced properly.

Tabel 1

Daylight opening	Turns
3000	10,0
2875	9,7
2750	9,3
2625	8,9
2500	8,5
2375	8,2
2250	7,8
2125	7,4
2000	7,0

IMPORTANT: The springs are under a large amount of pressure; always work carefully, especially when making corrections and use tensioners that fit and are maintained properly.

Tension the springs working from the bottom to the top! As a result of tensioning, springs should become thinner and longer (the number of revolutions x wire thickness). If this is not the case, exchange the left and right springs!

Procedure for tightening the springs.

1. Mark the spring with a straight line along its length.
2. Insert the first tensioner in the spring grip.
3. Rotate the first tensioner a quarter turn so that the spring becomes tighter.
4. Keep hold of the first tensioner and then insert the second tensioner in the next hole in the spring grip.
5. Rotate the second tensioner a quarter turn.
6. Keep hold of the second tensioner (take over the tension) and remove the first tensioner.
7. Repeat steps 3 – 4 – 5 – 6 until the correct tension is reached.
8. Fasten the spring grip to the shaft by tightening both the spring grip bolts with a torque of 27 to a maximum of 34 Nm.
9. Then remove the last tensioner.
10. Now check the number of revolutions that the spring has turned by counting the number of (separate) stripes on the spring.

To finish fitting your sectional door, remove the grips on the shaft and the vertical runners. Check whether the door is properly balanced. If this is not the case, follow the procedure in 4.12.

4.12 Correcting the spring tension

Block the shaft with mole grips. Secure the door in position so that it cannot move upwards. You can, for example, do this by securing mole grips on the vertical runners.

IMPORTANT: The springs are under a large amount of pressure; always work carefully, especially when making corrections and use tensioners that fit and are maintained properly.

Correct the springs by increasing or releasing the tension in maximum steps of one revolution per spring. When doing this, make sure that both springs are corrected by the same amount.

1. Insert the first tensioner in the spring grip.
2. Rotate the tensioner in the required direction.
3. Carefully loosen the spring grip bolts and take over the tension.
4. Keep hold of the first tensioner and then insert the second tensioner in the next hole in the spring grip.
5. Rotate the second tensioner a quarter turn in the required direction.

6. Keep hold of the second tensioner (take over the tension) and remove the first tensioner.
7. Repeat steps 4-5-6 until the required tension is reached.
8. Fasten the spring grip to the shaft by tightening both the spring grip bolts with a torque of 27 to a maximum of 34 Nm.
9. Then remove the last tensioner.

To finish fitting your sectional door, remove the grips on the shaft and the vertical runners.

4.13 Fitting the drive unit

To fit the drive unit, follow the instructions in the manual provided by the unit's supplier.

4.14 Adjusting the drive unit

To adjust the drive, follow the instructions in the manual provided by the unit's supplier.

4.15 Placing the CE mark

Now place the CE mark on an end cap at the bottom on the left or right.

See figure 17.

CE sticker



Fig. 17

5 Technical specifications

- LF 220 system with plastic corner bracket and torsion springs on the front
- Width: max. <5000 mm
- Door surface: max. 11 m²
- Weight: max. 162 kg
- Appendix A: garage door specifications
- The minimum safety level of the closing side must be in accordance with the requirements set in table 1 of EN 12453.
- Force measurements were carried out in accordance with EN 12445.
- The measured values remained under the maximum forces permitted under this standard.
- The respective measurements are available for inspection at the offices of Multi-Deur BV.
- Sound pressure: the sound pressure of the garage door is under the limit value of <70 dB.
- Temperature range: the garage door may be used within a temperature range of -20° to +40°C.

6 Installation and initial operation

The installation and initial operation of the garage door should be performed by an experienced fitter. The installation method must be recorded in writing. The company responsible for installing the garage door must provide the declaration of conformity and place the CE mark. The placement of the CE mark signifies that the garage door complies with the EU Machinery Directive.

7 Drive unit

The garage door is operated via the controllers built into the drive unit. See the drive unit manual for further details. When the door is initially operated, the customer (user) must receive adequate instruction.

7.1 Electrical drive unit

The electrical drive unit is steered via a remote control or a wall-plug switch. The impulse signal is always given facing the door. The power limiter integrated in the drive unit will detect obstacles encountered by the door sections as they move through a cycle. If this occurs, the unit will stop and then move the door back in the opposite direction.



No locking devices may be fitted on the garage door.

The drive unit settings may only be changed by an experienced fitter.

7.2 Manual operation

If there is a power failure, the door can be disengaged from the drive unit via the emergency lock. In this situation, the door can be opened and closed by hand.

The door may only be opened or closed manually with the handgrip.



If the garage does not have a second entrance, an emergency lock must always be fitted.

8 Maintenance

A long lifespan can only be guaranteed with regular maintenance, care and inspections.

8.1 General

If maintenance is not carried out, neglected or performed by an inexperienced fitter, the company that installs this garage door cannot be held liable for the consequences.



8.2 Care

The following measures must be carried out:

- Immediately after installation:
- A drop of oil must be applied to all hinges, runners and bearings.
- Lubricate the bearing roller shafts.
- Lubricate the cables.
- Lightly oil the torsion springs.

Additional maintenance and inspection work:

- At least once per year, check whether all nuts, bolts and screws are still secure. Tighten them if necessary.
- Check components such as cables, runners, etc. for wear, cracks and if necessary have them replaced by an experienced fitter or specialist company.

- Make sure that the spring tension is correct. If the spring tension has to be adjusted, follow the procedure in 4.12 (correcting the spring pressure) (this operation may only be performed by an experienced fitter or specialist company).
- Have the torsion springs and steel cables replaced after approximately 15000 cycles (if the door is opened and closed 8 times a day, this will be after approximately 5 years).
- Regularly perform visual checks for damage (unless specified otherwise by the supplier, in general, 1x per month with up to 50 cycles per week).
- If the door movement cycle is erratic and the drive unit does not detect any obstacles, inspect the door using a safe method! Pay particular attention to cables, springs and rails with bearing rollers! Never repair or replace any components on your own; have this done by an experienced fitter or specialist company.
- Clean the runners once per year.

Inspection/service

According to Chapter 6 of the Directive “Guidelines for powered windows, gates and doors”, powered windows, gates and doors must be inspected, from the first time they are used and in line with the service interval specified by the supplier, but at least once per year, by an experienced fitter or specialist company.

This inspection is not part of the normal maintenance routine.

8.3 Troubleshooting

Problem	Possible cause	Solution
The door does not open/close.	Plug not inserted in socket.	Insert plug.
The door does not open/close.	Obstacle in the way, dirt in the runners.	Remove obstacle, clean the runners.
The door does not open with the remote control.	Remote control defective or the battery is empty.	Replace the remote control or battery.
The drive unit works but the door does not move.	The drive unit is disengaged.	Engage the drive unit.
Other problems related to the drive unit.		See the drive unit manual for further details.

9 Putting the door out of operation/dismantlement/disposal

9.1 Putting the door out of operation (only applies to electrically powered models)

Pull the plug out of the wall socket and remove it from the power cable so that it can no longer be used.

9.2 Dismantlement

General:

- The door may only be dismantled by people who are qualified to do so.
- Make sure that only these people are near the door when it is dismantled and keep others at a safe distance, if necessary by placing a safety ribbon around the garage.
- Make sure that there is sufficient illumination when the door is dismantled.
- When releasing the springs, make sure that you use the correct tools and that you have a firm footing.

Procedure:

Block the shaft with mole grips.

Secure the door in position so that it cannot move upwards. You can do this by placing mole grips on the vertical runners.

IMPORTANT: The springs are under a large amount of pressure; always work carefully, especially when making corrections and use tensioners that fit and are maintained properly.

1. Insert the first tensioner in the spring grip.
2. Take hold of the first tensioner and carefully loosen the spring grip bolts and take over the tension.
3. Then place the second tensioner in the next hole in the spring grip and carefully release the spring. The springs are in principle tensioned from top to bottom.
4. Insert the first tensioner back in the spring grip and release slightly more tension.
5. Repeat steps 3-4 until all the tension on the spring is released.
6. Repeat steps 1-4 working on the other spring.
7. Loosen the bolts on the cable drums and remove the steel cables.
8. Dismantle the shaft and springs.
9. Loosen the nuts and bolts on the connector between the plastic corner bracket and the horizontal rails.
10. Dismantle the door hanging and slide the horizontal rails out of the plastic corner bracket.
11. Dismantle the panel sections working from the top down by loosening the runner holders and centre hinges.
12. Dismantle the plastic corner bracket.
13. Remove the back hangs.

9.3 Disposal

All the garage door components can be easily dismantled and recycled. Take components that are no longer used to an official waste disposal company.

10 The manufacturer



Multi-Deur BV

Nijverheidsweg 25
3899 AD Zeewolde

Tel.: +31 (0) 36 – 522 48 11
Fax: +31 (0) 36 – 522 48 79

Information: info@multi-deur.nl
Sales: verkoop@multi-deur.nl
Service: service@multi-deur.nl

Internet: www.multi-deur.nl